

# HIGH-PRESSURE PISTON COMPRESSOR

DM (350 bar / 30-37 kW)



*Atlas Copco*





## ***PEAK PERFORMANCE COMPRESSION SYSTEMS***

Atlas Copco manufactures high-end premium products engineered by a world-class center of excellence. Our commitment to quality is exemplified by compliance with ISO 9001, ISO 14001 and OHSAS 18001 certifications. We have a century of experience in high-pressure technology and have installed thousands of compressors worldwide for various industrial gas and vehicle refueling applications. Our DM high-pressure oil-free compressor range will meet your needs for peak performance and optimal efficiency.

## ***HIGH-PRESSURE, HIGH RELIABILITY, AND NO OIL CARRY-OVER***

The DM compressor range utilizes Atlas Copco's revolutionary high pressure oil-free compression. It prevents oil from contaminating the gas. And it eliminates concerns about oil disposal contaminating the environment. The hermetically sealed compressor-motor unit with magnetic coupling ensures no gas losses to the atmosphere. The unique vertical design of these 2-5 stage compressors is especially designed for diverse gas compression applications where space is at a premium.



## **DM HIGH-PRESSURE OIL-FREE COMPRESSORS**

DM compressors are grease lubricated compressors with oil-free cylinders, incorporating innovative scotch yoke technology in a vertical design. Completely gas-tight, they are perfectly adapted to applications such as natural gas vehicle refueling stations, natural gas grid boosting and hydrogen compression for various end uses and processes.

### **Oil-free**

With its unique scotch yoke design converting rotating movements into linear movements, the DM compressor does not require lube oil, hence will not contaminate the compressed gas with oil carry-over. It also does not require oil disposal processes, or power consumption for crankcase heaters in cold weather.

### **Gas-tight**

The hermetically sealed pressurized crankcase means that the DM compressor is absolutely gas-tight. No gas will leak to the atmosphere and no gas contamination from the outside is possible. The suction process starts directly from the pressurized crankcase with a range from atmospheric pressure up to 39 bar(a) inlet pressure.

### **Easy maintenance**

Thanks to the magnetic coupling, the compressor block can be easily dismantled and replaced on site in less than a half a day. The dismantled compressor block will then be refurbished in the factory to guarantee the shortest downtime and maximum availability.

# SAFE FOR GAS APPLICATIONS

The DM compressors are safe for any gas application and fully comply with ATEX and PED regulations.

1

## Highly efficient: 2 to 5 compression stages

- DM compressors are available with up to 5 compression stages to ensure low compression ratios, reduced heat generation, and less wear.
- Scotch yoke technology ensures balanced forces and reduced floor space.

2

## Gas cooler

After each compression stage the gas is cooled by fins around the gas pipes.

3

## Cooling air fan

Directly coupled to the main drive to ensure a constant air flow through the whole unit.

4

## Cooling air channel

Ensures optimal cooling air flow through the complete compressor.

5

## Electric motor drive

- The drive is coupled at the bottom with a cooling air fan and at the top with a magnetic coupling.
- Available for Zone 2, and optionally for Zone 1.

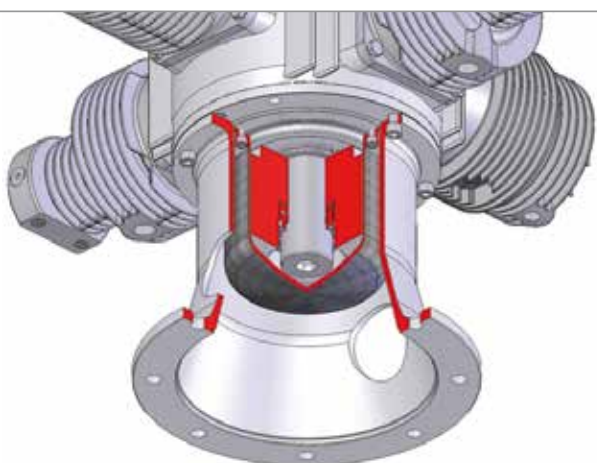

6

## Magnetic coupling

The shaft is completely integrated in a hermetic housing with magnets ensuring rotation. This eliminates risk of gas leakage, prevents wear, and eases dismantling.

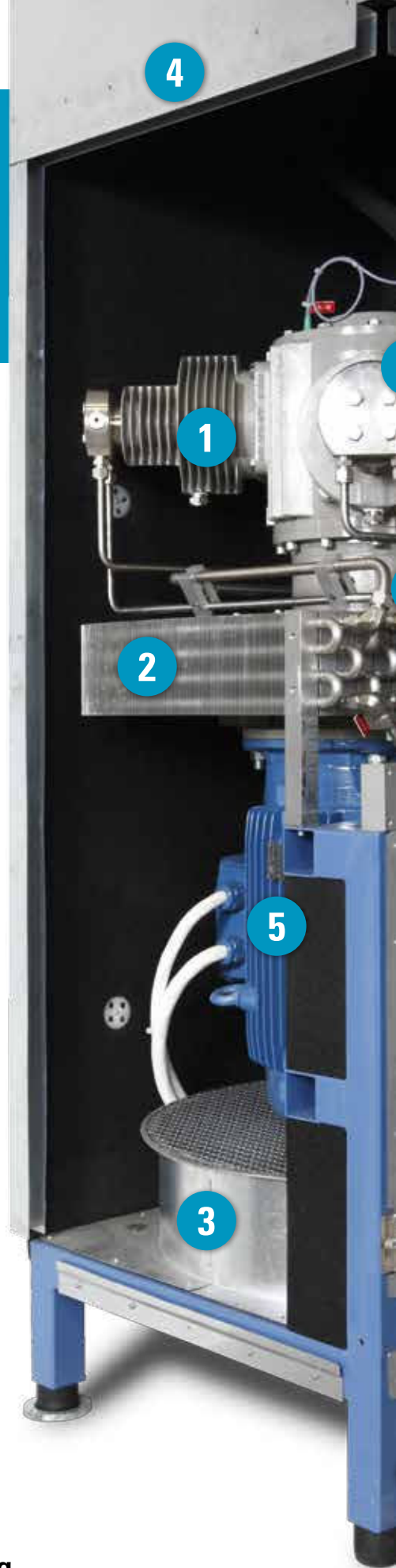

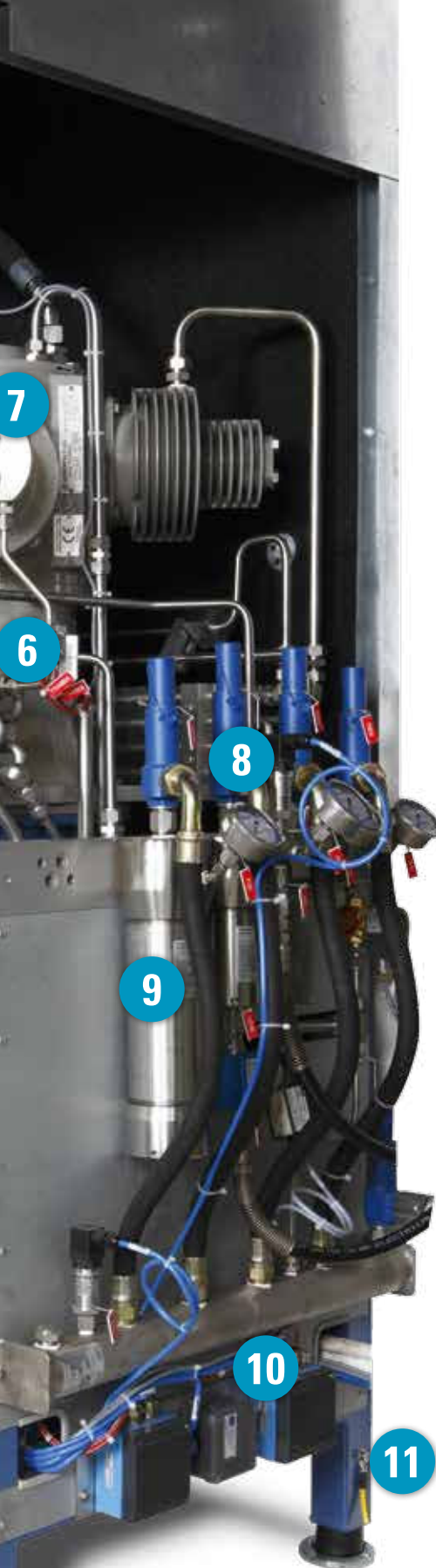

7

### Hermetically sealed pressurized crankcase

- Trunk piston technology enables the cylinders to fit on the crankcase.
- Suction process starts directly from the pressurized crankcase with up to 39 bar(a) (551 psig).
- No need for distance pieces, gaskets or stuffing boxes.

8

### Pressure relief valves

A set of relief valves and gauges on inter-stage and discharge side for optimized safety.

9

### Separator after last compression stage

Interconnection gas pipes in stainless steel.

10

### Relief valve collector

Each individual stage is collected back to suction.

11

### Anti-vibration pads

DM compressors are assembled on a vertical frame, isolated from their support by vibration dampening elements. No special foundations are required.

12

### Vertical frame

All elements are assembled on a steel base frame. The vertical design allows an extremely small footprint of only 0.7 m<sup>2</sup> (7.5 sqft).

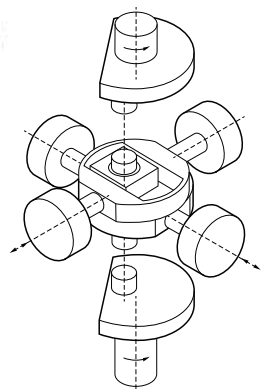

### Scotch yoke principle for balanced forces

The choice of a scotch yoke as reciprocating motion allows the conversion of the rotational motion of the prime drive into a linear motion. The reciprocating parts are directly coupled to a sliding yoke which allows a perfectly balanced centric drive in an extremely compact format. Reduced frictions, smoother operation and more power delivery are the resulting benefits.

12

# OPTIMAL CONTROL OF YOUR COMPRESSION SYSTEM



The control unit is a fail-safe electronic board specifically developed to control compressors and their system components. It allows fail-safe solutions to be set up quickly and with minimal maintenance requirements. It eliminates the need for complex circuitry for monitoring systems (e.g. for suction pressure or final output stage temperature).

Monitoring functions allow operators and service personnel to identify and rectify problems quickly and effectively. This increases system availability and significantly reduces maintenance and servicing costs.

## STANDARD SCOPE AND FEATURES

Whether you require a complete installation or a 'packager-ready' unit, please consult us to define the optimum solution.

Compression unit	2 to 5 stage oil-free compression
	Frame mounted with vertical arrangement
	Hermetically sealed crankcase
	Electric motor 1450 rpm – start delta starter
	Power transmission by magnetic coupling
	Zone 2 classification
	Stainless steel tubing and inter stage air cooler
	Set of gauges and safety valves on inter stage and discharge side
	Power transmitter on discharge side
	Separator after last compression stage
	Direct-driven cooling air fan
	Cooling air ducting for free-standing operation
	Installed on common steel base frame
	Anti-vibration pads
	PED/ATEX conformity
Standard scope	CE certificate
	Instruments wired to junction box
	Control cabinet for installation in non-hazardous area
	Starting equipment (soft starter or start with frequency converter)
	Suction filter 10 microns (loose)
Options	Pressure maintenance valve (loose)
	H2 execution
Engineered models	441 bar(a) execution

*The DM compressor is ideal for CNG stations. We can provide a complete package with one or two compressors.*

# TECHNICAL SPECIFICATIONS

## Technical data

Suction pressure	CNG: Up to 39 bar(a) H2: up to 10 bar (a)
Working pressure	CNG: Up to 301 bar(a) H2: up to 350 bar(a)
Flow rate	Up to 200 Nm <sup>3</sup> /h
Motor power	30 kW (37 kW)
Size	900 x 740 x 1700 mm (35.4 x 29.1 x 66.9 inch)
Weight	ca. 800 kg (1763 lbs)
Gases	CNG, CH <sub>4</sub> , biogas, hydrogen

## Compressor capacity for natural gas (Ts= 15°C/Ta=20°C)

Flow (Nm<sup>3</sup>/h)

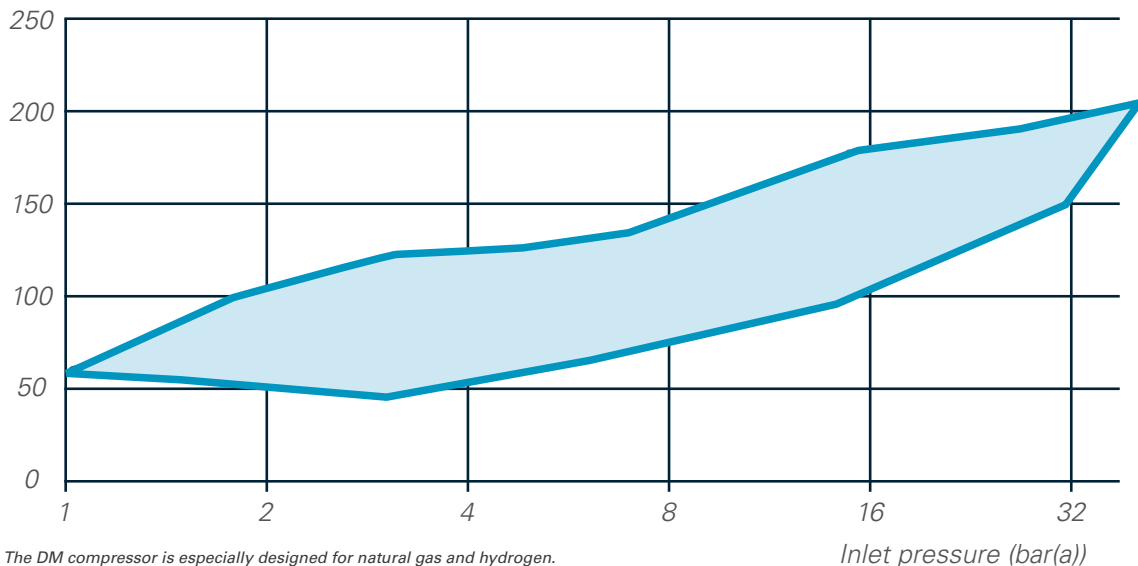

The DM compressor is especially designed for natural gas and hydrogen.  
The diagram above illustrates standard DM compressors compressing natural gas.  
Hydrogen or process data outside the above range are available upon request.

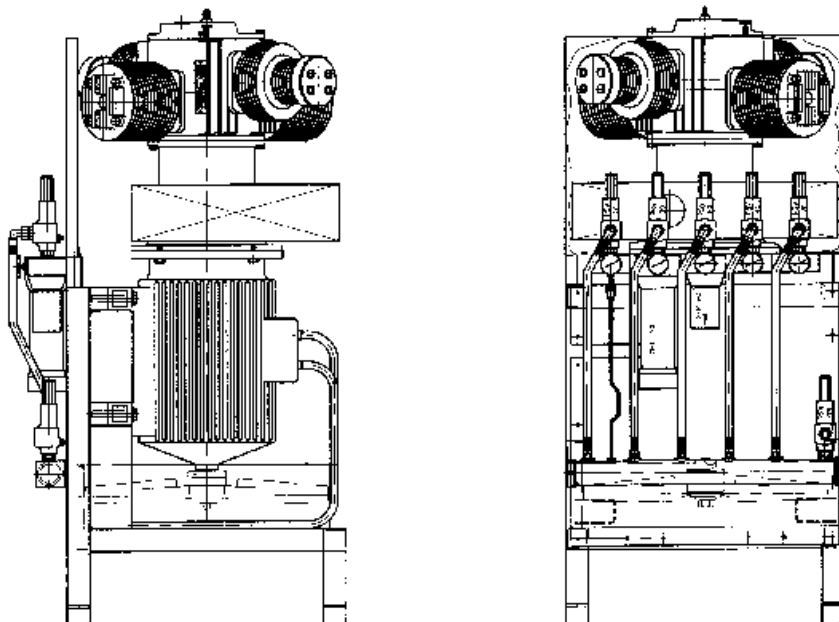

## COMMITTED TO SUSTAINABLE PRODUCTIVITY

We stand by our responsibilities towards our customers, towards the environment and the people around us. We make performance stand the test of time. This is what we call – Sustainable Productivity.



[www.atlascopco.com](http://www.atlascopco.com)